

*Belair*  
Product Range  
**2007**



**Date: 7/02/2007**

CE certificate, C-Tick, CCC certificate, GS certificate



# Company Profile

**DIGICOLOR** is an Australian Owned international company headquartered in Brisbane, Queensland, Australia. Established in 2005 as an "Australian Owned" Company specialising in Direct From China Product Sourcing to the Building and Construction industry here in Australia.

- ◇ **Direct From China to the Trade in Australia**
- ◇ **'DIGICOLOR' is an Australian Owned Brand**
- ◇ **Australian Certified Products: C-Tick, CE**

**Tel: 1300 657 811    Fax: +61 7 3262 2226**

**Web:     [www.digicolor.com.au](http://www.digicolor.com.au)**

**Email:   [info@digicolor.com.au](mailto:info@digicolor.com.au)**



## Quirky facts

Australia imports more goods than it exports. As a result, Australia has a \$722 million trade deficit according to the latest figures from the Australian Bureau of Statistics (ABS).

According to the ABS, Australia imported \$18,500 billion worth of goods between April - June 2006 (while it exported goods worth \$17,850 billion – an improvement of one per cent in previous trade deficit figures).

Big-ticket items include non-industrial transport equipment, textiles, clothing and footwear and consumer goods.

*Source: International Trade in Goods and Services, Australia, ABS Jun 2006*



## ABOUT OUR COMPANY

**DIGICOLOR** offers the "TOTAL PRODUCT SOURCING SOLUTION – DIRECT FROM CHINA" for your business. We are general importer's supplying a large range of products and Building Materials to various clients in the Building and Construction industry here in Australia.

### Consumer OEM Products:

- ◆ **Electronic devices and appliances:**
  - ◇ **Kitchen Appliances**
    - ◇ RANGEHOODS
    - ◇ COOKTOPS
      - ◇ INDUCTION
      - ◇ GAS
      - ◇ ELECTRIC - Ceramic
    - ◇ OVENS
    - ◇ DISHWASHERS
    - ◇ Microwave Ovens
  - ◇ **Home Appliances**
    - ◇ Audio & Video
    - ◇ Plasma & LCD's
    - ◇ Steam Station Irons
    - ◇ Irons
    - ◇ Ironing Centre's
    - ◇ Laundry Tubs
  - ◇ **Computer devices**
- ◆ **Building materials (EXAMPLES)**
  - ◇ Stainless Steel Pipes/ Coils
  - ◇ Aluminium Windows
  - ◇ Cement
  - ◇ Tiles
  - ◇ Doors etc
- ◆ **Food Ingredients**
- ◆ **Clothing**
- ◆ **Furniture**
- ◆ **Medical supplies**

**DIGICOLOR** are able to source almost any manufactured item or material, or, if you have an idea for a new product we can have it made by a reputable manufacturer to your design and to the relevant Australian Standards. **DIGICOLOR** will help your business by **saving time** and **money** in the sourcing process and avoid many costly mistakes by providing product samples or material samples.

Digicolor also offer a "FREE QUALITY ASSURANCE GUARANTEE SERVICE", allowing our clients get the solution they need the first time.

**DIGICOLOR** will source, quote and supply as per our client's specific requirements. We have an extensive supplier base across Asia especially CHINA!

- ◇ **DIRECT CO-OPERATION WITH FACTORIES IN CHINA**
- ◇ Reduced "Time to Market" in Australia



---

## **TOTAL PRODUCT SOLUTIONS: ADVANTAGES**

---

- ◆ **DOOR TO DOOR PRODUCT SOURCING TO CUSTOMER'S SPECIFICATIONS**
- ◆ **EFFICIENT & EFFECTIVE CLEAR COMMUNICATION**
  - ◇ **DIGICOLOR** has staff permanently based in Hong Kong, China and Australia who control our product sourcing and supplier relationships in:
    - ◇ **Greater China Region including:**
      - ◇ **China**
      - ◇ **Hong Kong**
      - ◇ **Taiwan**
  - ◇ Our staff has many years experience in product sourcing/trading and manufacturing and have been educated and lived in Australia for long periods of time so there is no cultural or language barriers.
- ◆ **ON-DEMAND/ONSITE QUALITY INSPECTION SERVICE (See below)**
  - ◇ **Quality Assurance Guarantee**
    - ◇ Minimum Defect rate
    - ◇ Maximises Shipment Quality
- ◆ **AUSTRALIAN CERTIFICATION OF PRODUCTS**
- ◆ Reduced "**Time to Market**" in Australia
- ◆ **OFFSHORE MANUFACTURING AND PRODUCT DEVELOPMENT**
  - ◇ **CONFIDENTIALITY:**
    - ◇ All information, designs and resources provided by our customers will be kept confidential
    - ◇ To ensure **Exclusive Products in the Market**
- ◆ **SHIPPING AND IMPORTING INCLUDING CUSTOM CLEARANCE**
  - ◇ We deliver to your business **anywhere in Australia**
- ◆ **DIRECT CO-OPERATION WITH FACTORIES IN ASIA: (Especially China)**
  - ◇ **DIGICOLOR** works with factories throughout China, Hong Kong and Taiwan... (Shen Zhen, Jiangsu, Zhejiang, Guangdong, Chongqing, Beijing, Shanghai, Xian, Guangzhou, ...)



---

## QUALITY ASSURANCE GAURANTEE

---

### **IN-PROCESS INSPECTION: *Free Inspection Service!***

In-Process Inspections offer a very high-level of quality control because problems uncovered during the actual production-run can be more easily resolved. This is largely because addressing quality issues prior to the seller incurring the entire production-run expense makes it much more likely the seller will be willing to resolve problems and do so without suggesting additional charges to you.

#### **DIGICOLOR Suggests: *"This service is free of Charge"***

*To ensure there is no Quality issues such as shipment delay, product reworking expense, or an unwanted confrontation with the factory regarding acceptability. An FSI should also be performed along side to ensure product quality.*

### **Final Shipment Inspection (FSI) *Free Inspection Service!***

Final Shipment Inspections take place after production is complete either at the production facility itself or much less frequently at the forwarder's warehouse. If the FSI is performed at the production facility, then problems can be more easily managed. However, if the FSI is conducted at the forwarder's warehouse, then a seller will usually be less willing to resolve quality issues.

#### **DIGICOLOR Suggests: *"This service is free of Charge"***

*The FSI is an essential step in the Quality Assurance process. Helps overcome issues such as shipment delay, product reworking expense, or an unwanted confrontation with the factory regarding poor quality and acceptability of the product.*

### **Container Loading Supervision (CLS) *Free Inspection Service!***

**DIGICOLOR** provides Container Loading Supervision which assures the importer-buyer that the goods ordered are indeed the same goods to be placed on the container and that the goods ordered are entirely placed in the container and in a way the buyer has stipulated the goods be loaded. A full quantity check and quality spot check can also be performed during this process.

#### **DIGICOLOR Suggests: *"This service is free of Charge"***

*This service overcomes issues such as short-shipment (the loading of fewer items than ordered) or loading incorrect items or loading the items incorrectly. A "spot" check inspection can also be performed during the CLS; however it will not be as detailed as a dedicated FSI.*



---

## **SHIPPING / TRANSPORT**

---

### **International**

Allow a minimum six weeks shipping time from date of order to delivery. This can vary depending on the commodity & supplier. Specific lead times would be advised at time of order & progress updates provided weekly.

### **Domestic**

**DIGICOLOR** can deliver to your location anywhere in Australia.

---

## **PAYMENT TERMS**

---

All supplier research, sourcing, quality assurance and quotes are free of charge to the client.

Commodity samples are supplied on request at cost.

When an order is placed a 50% deposit is required (Negotiable). The balance is payable on a 14 day invoice from receipt of goods.

For new clients, or for specialty items, a deposit of 75% may be required.

---

## **BUSINESS HOURS**

---

**DIGICOLOR** is committed to making things easier for our customers, and we understand that not all business can be conducted during business hours. To this end we are available on **1300 657 811** seven days a week or we can be contacted via:

---

## **HEAD OFFICE LOCATED IN AUSTRALIA**

---

### **BRISBANE HEAD OFFICE**

5/139 Sandgate Road,  
ALBION, BRISBANE, QLD, 4010



Kitchen Products

## BELAIR PRODUCT RANGE

## **BELAIR – BGCS60: 60CM – BUILT IN GAS COOKTOP**

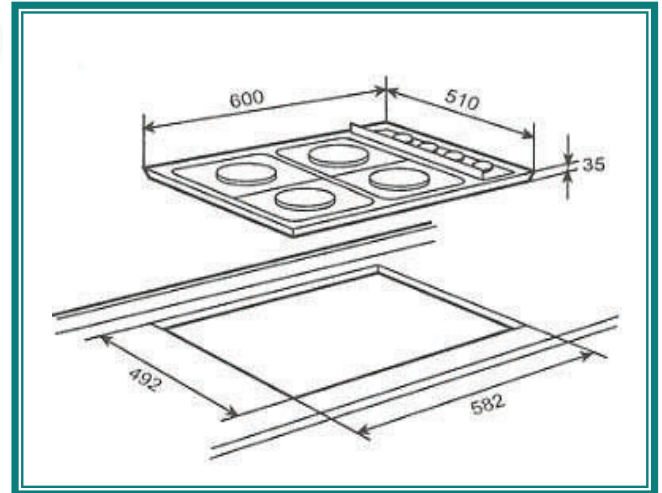

**Model: BGCS60 60CM – BUILT IN GAS COOKTOP**

**Product size:** 600mm Width x 519mm Depth x 35mm Height

**About Product:**

### **Features:**

- ◇ 4 gas burner
  - 1 fast burner
  - 1 auxiliary burner
  - 2 semi fast burner
- ◇ Enamelled steel trivets
- ◇ Electric ignition  
Stainless chrome knobs  
(same as oven)

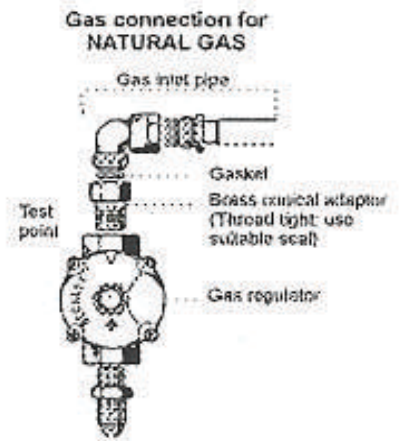

### **Installation instruction:**

- ◇ Set for natural gas, LPG jets provided
- ◇ Fuse rating: 10 amp plug
- ◇ Slimline design

### **Colours available:**

- ◇ Stainless Steel

### **Approval Numbers:**

- ◇ Approval No: 6480
- ◇ Approval expires: 2008

## **BELAIR – BECS60: 60CM – ELECTRIC COOKTOP**

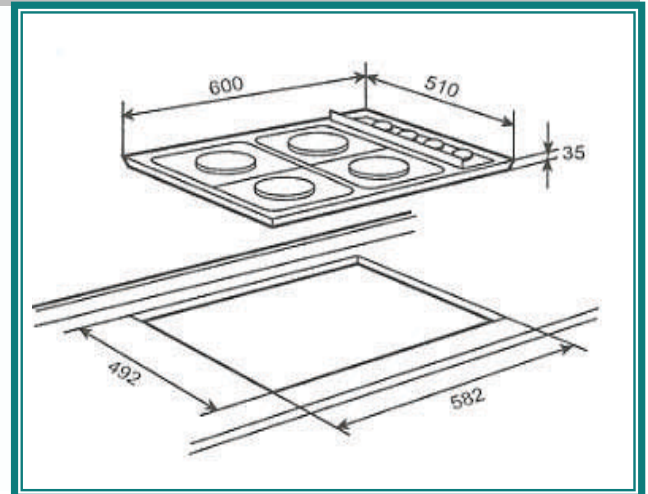

**Model: BECS60 – 60CM – ELECTRIC COOKTOP**

**Product size: 600mm Width x 519mm Depth x 35mm Height**

**About Product:**

**Features:**

- ◇ 4 solid electric elements
  - 1 x rapid 2000w element (180mm)
  - 1 x rapid 1500w element (145mm)
  - 1 x normal 1500w element (180mm)
  - 1 x normal 1000w element (145mm)
- ◇ Rapid plate x 2
- ◇ Satin chrome knobs
- ◇ Warning light indicating that one or more plates are operating
- ◇ Dimensions 580mm x 500mm

**Installation instruction:**

- ◇ Fuse rating: 25 amps – hard wiring
- ◇ Slimline design for easy installation

**Colours available:**

- ◇ Stainless Steel

**Approval Numbers:**

- ◇ Approval No: Q041833
- ◇ Approval expires: 2008

## **BELAIR – BCCS60: 60CM – ELECTRIC CERAN COOKTOP**

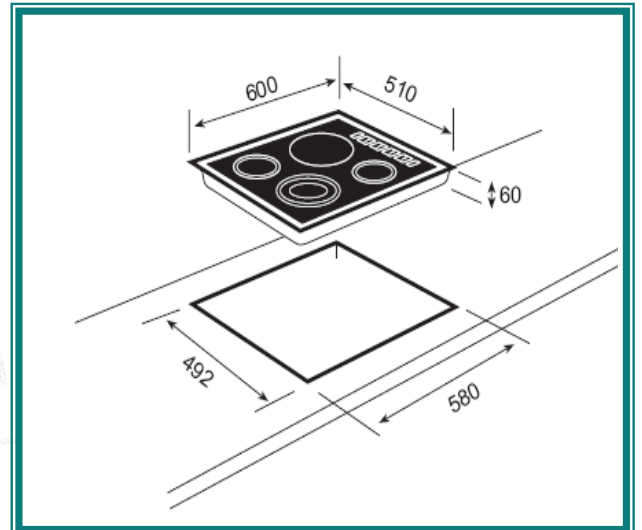

**Model: BGCS60 60CM – BUILT IN GAS COOKTOP**

**Product size:** 600mm Width x 519mm Depth x 35mm Height

**About Product:**

### **Features:**

- ◇ Vitroceramic cooktop
- ◇ Polished edge (no surround)
- ◇ Lateral control knobs
- ◇ Dimensions 600 x 510 mm
- ◇ 4 cooking zones:
  - 2 x 1800 w element (180mm)
  - 2 x 1200 w element (145mm)
- ◇ Residual heat indicators
- ◇ Maximum nominal power 6000 W

### **Installation instruction:**

- ◇ Fuse rating: 25 amps – hard wiring
- ◇ Slimline design for installation above Belair Oven

### **Colours available:**

- ◇ Frameless black ceran

### **Approval Numbers:**

- ◇ Approval No: Q050924
- ◇ Approval expires: 2008

## **BELAIR – BFFS60: 60CM – FAN FORCED OVEN**

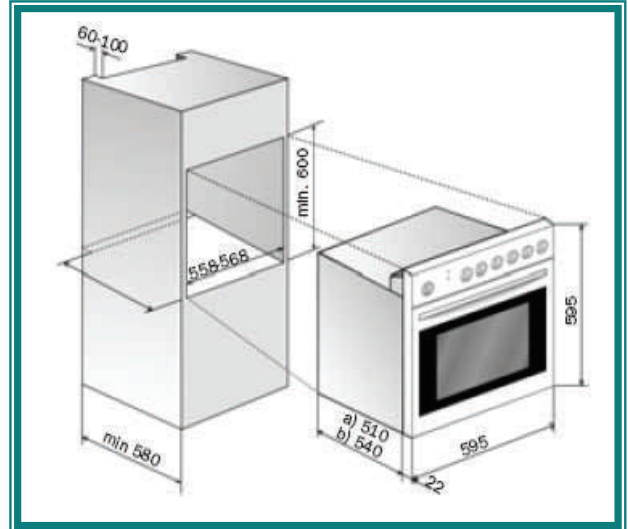

**Model:** **BELAIR – BFFS60: 60CM – FAN FORCED OVEN**

**Product size:** 600mm Width x 519mm Depth x 35mm Height

**About Product:**

**Features:**

- ◇ 4 Cooking functions
- ◇ Cooling fan and mix chamber refrigeration system to evacuate steam
- ◇ Steam outlet through vault
- ◇ Dual glazed door design
- ◇ Stainless chrome knobs (matching hob)
- ◇ Separate knob position
- ◇ Stainless steel wide metallic handle
- ◇ High quality door hinges for ease of opening
- ◇ Oven volume is 56 litres of useable space
- ◇ Net space Width = 419mm/ Depth = 395/ Height = 320mm (according to standards)
- ◇ Crystal clean enamelled cavity
- ◇ Closed door grilling
- ◇ Lamp indicator on thermostat function dial
- ◇ Inner light / oven power indicator

**Installation instruction:**





- ◇ Under bench or wall mounted installation
- ◇ Fuse rating: 15amp

**Colours available:** Stainless Steel

## BELAIR – BFFS60: 60CM – FAN FORCED OVEN

### COOKING FUNCTIONS

#### Cooking Functions:

	Fan Forced		Fan Grill
	Full Grill		Defrosting

#### Standard accessories:

- ◇ 1 x safety oven wire rack
- ◇ 1 x deep tray (50mm) with crystal clean enamel
- ◇ Chromed tray support

#### Approval Numbers:

- ◇ Approval No: Q051251
- ◇ Approval expires: 2010. 08. 24

## BELAIR – BFFS60: 60CM – FAN FORCED OVEN

### INSTALLATION DIAGRAM

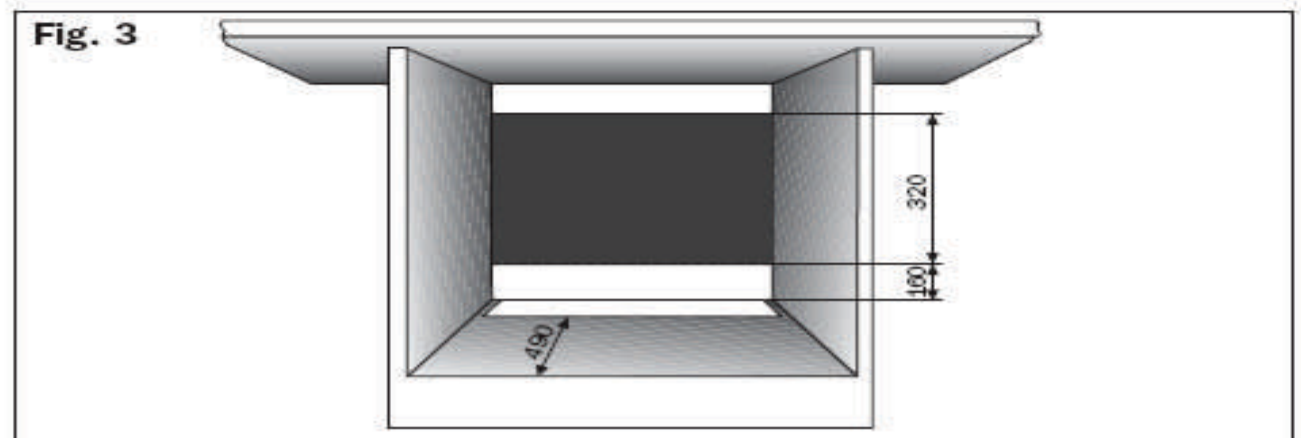
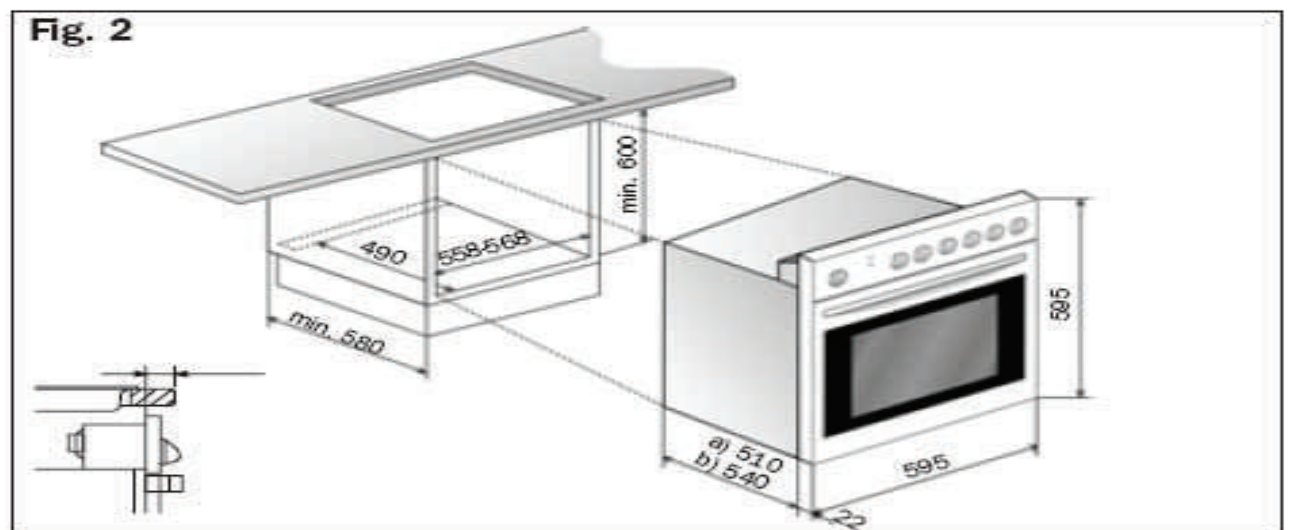
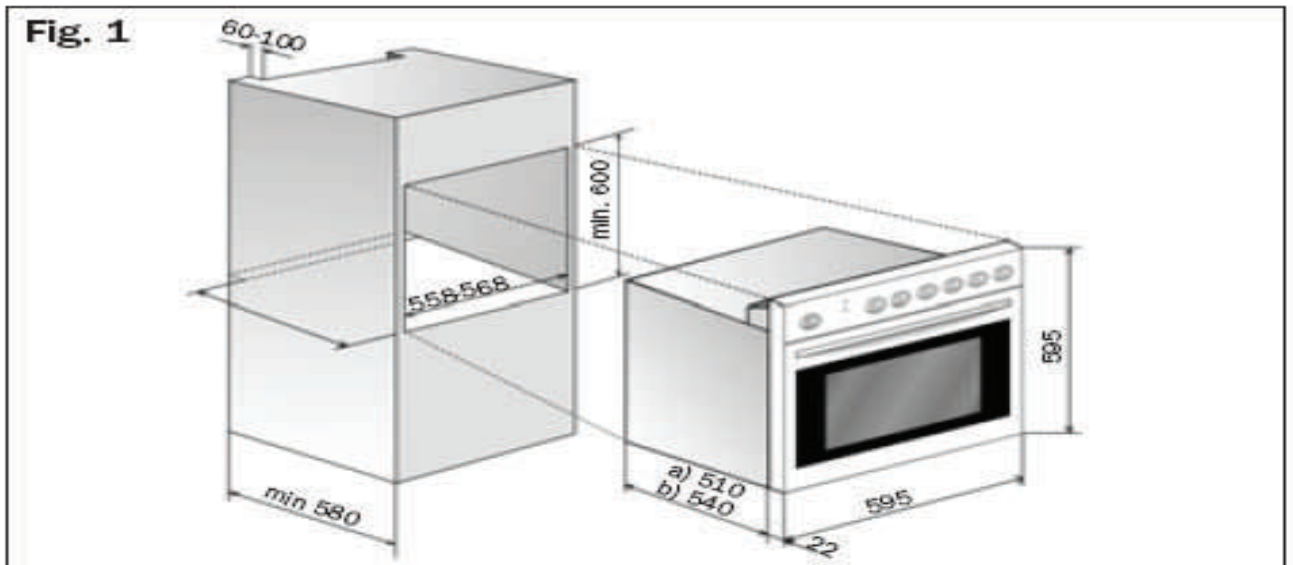

## **BELAIR – BC6GW – 600X400X505MM – RANGEHOOD**



### **Installation instruction:**

- ◇ High product performance
- ◇ Experienced Technical Staff
- ◇ Guarantee/Warranty
- ◇ CE, GS, CB certificate,
- ◇ Customized Services

### **Colours available:**

- ◇ Stainless Steel

### **Approval Numbers:**

- ◇ Approval No: Q041833
- ◇ Approval expires: 2008

**Model: BC6GW – 600X400X505MM – RANGEHOOD**

**Product size: 600mm** Width x **400mm** Depth x **505mm** Height

### **About Product:**

#### **Key specification/ Features:**

- ◇ European Styled Design
- ◇ Flat Aluminum Filter
- ◇ Touch Control

**Finish:** stainless steel and 6mm tempered glass

**Two speed motor:** 200W

**Lamps:** 2x10w

**Air capacity:** 660m<sup>3</sup>/h

**Air outlet:** 150mm

**N.W:** 16kg

**G.W:** 20kg

**Qty:** 180 pcs/20FCL,  
372 pcs/40FCL,

## **BELAIR – WIP60: INDUCTION – 60CM, 75CM, 90CM**

### **INDUCTION HOBS: 60CM, 75CM, 90CM**

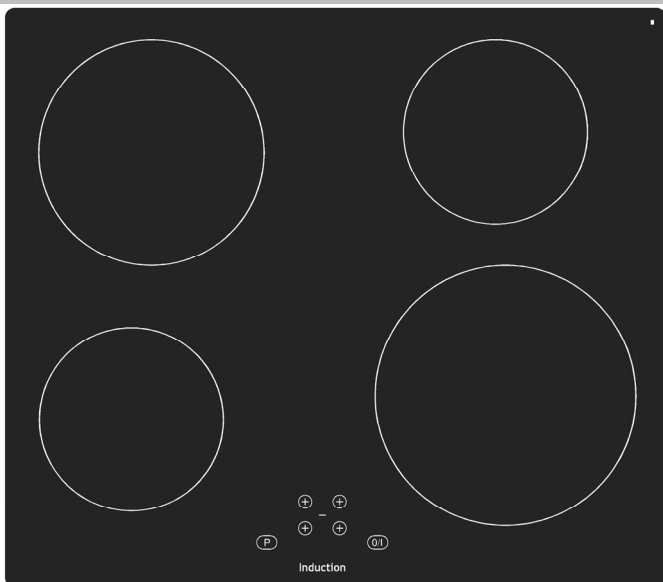

#### **Colours available:**

- ◇ Black Glass

#### **Model: BELAIR – WIP60: INDUCTION – 60CM, 75CM, 90CM**

**Product size:** 560mm Width x 490mm Depth x 48mm Height  
750mm Width x 490mm Depth x 48mm Height  
940mm Width x 449mm Depth x 48mm Height

**About Product: INDUCTION – 60CM, 75CM, 90CM**  
**(Refer to European Cut Out Sizes Below – Far Right)**

Innovation and ergonomics are the key characteristics of the Belair Induction Hobs. The many advantages of cooking with induction are as follows:

- ◇ Excellent responsiveness to changes in heat settings – almost instantaneous reaction to decreasing or increasing heat.
- ◇ Much quicker cooking time – takes about half the time of other cooktops to boil water.
- ◇ Loss of heat to the environment is minimal, because nearly all the heat is induced in the pan, as opposed to other methods of cooking where the heat source is external to the pan.
- ◇ The touch controls on the models we tested have specific settings that make it clear what power level is set, and the setting is very accurate.
- ◇ The cooktop surface doesn't get as hot as other electric cooktops, thus reducing the chance of burns, and is much quicker to cool down. This also means most spillages won't bake on, smoulder or ignite, although you do have to be careful about sugar and foil. High settings will still leave the element too hot to touch.
- ◇ More energy-efficient than other types of cooktop.
- ◇ Capable of detecting if a saucepan has boiled dry: some models automatically turn off, while others turn down.
- ◇ If the pan you use is incompatible or you forget to put one on the hob, it will indicate the error and won't heat up.
- ◇ Easy to keep clean, as there are no knobs to clean around and hardly any other dirt traps.

**Model: BGCS60 60CM – BUILT IN GAS COOKTOP**

**Product size:** 600mm Width x 519mm Depth x 35mm Height

**About Product:**

**Induction Generation 4**

**Total power:** 74000 W

**4 boosters:** 3300 - 2500 - 1800 - 1800 W

**Diameters:** 210 - 180 - 145 - 145 mm

**4 heating zones:** 2300 - 1850 - 1400 - 1400 W

Ergonomic front control panel

**Safety:**

- ◇ Pan detection
- ◇ Over temperature cut off
- ◇ Locking touch
- ◇ Residual heat indicators
- ◇ Automatic stop
- ◇ Over spillage stop

**Colours Available:** Black Glass

**Sizes Available:** 60cm, 75cm, 90cm

**Country of Origin:** Denmark

**Warranty:** 2 Years including Parts and Labour

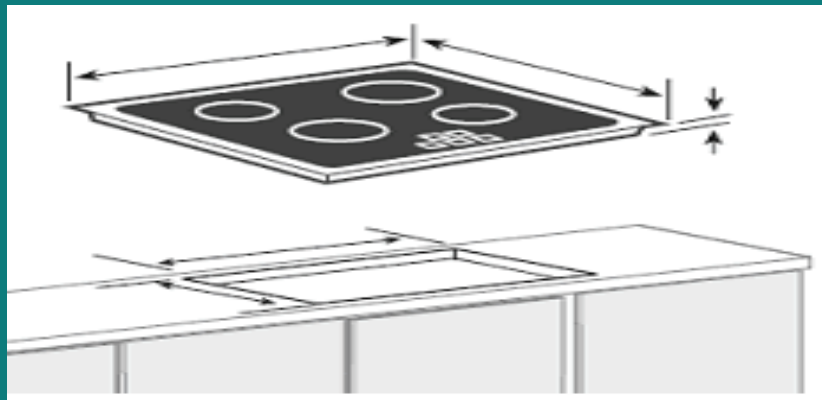

	<b>60cm:</b>	<b>75cm:</b>	<b>90cm:</b>
<b>Cut-out:</b>	560 x 490mm	750 x 490mm	940 x 440mm
<b>Casing thickness:</b>	48mm	48mm	48mm
<b>Glass size:</b>	590 x 520 mm	780 x 520 mm	970 x 460 mm

**Approval Numbers:**

- ◇ Approval No: Q041833
- ◇ Approval expires: 2008

## **Digicolor Pty Ltd**

**Head Office:** 5/139 Sandgate Road  
ALBION, QLD 4010, AUSTRALIA

**PO Box:** PO Box 801,  
ASPLEY, QLD 4034, AUSTRALIA

**Tel:** 1300 657 811

**Fax:** +61 7 3262 2226

**Web:** [www.digicolor.com.au](http://www.digicolor.com.au)

**Email:** [info@digicolor.com.au](mailto:info@digicolor.com.au)